

78265

	Part Number	Thermal Resistance °C/W at 3in length	Width in	Height in	Surface Area in/in	Weight lb/ft
	78265	8.74	0.87	1.12	8.0	0.30

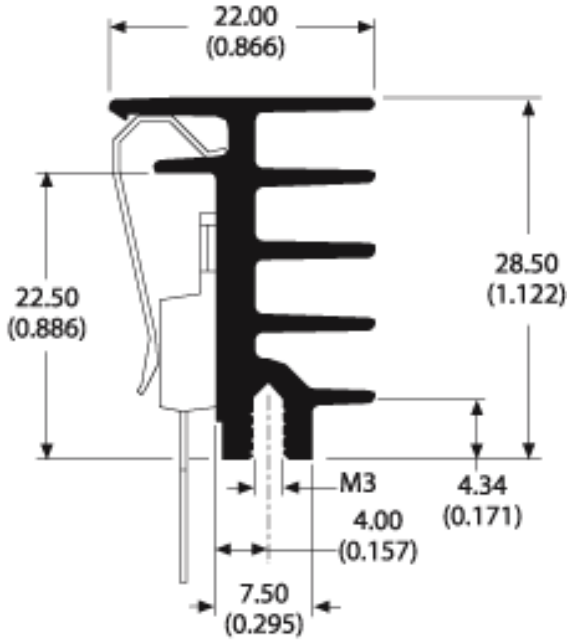

### Natural Convection

Heat Sink Temperature Rise Above Ambient

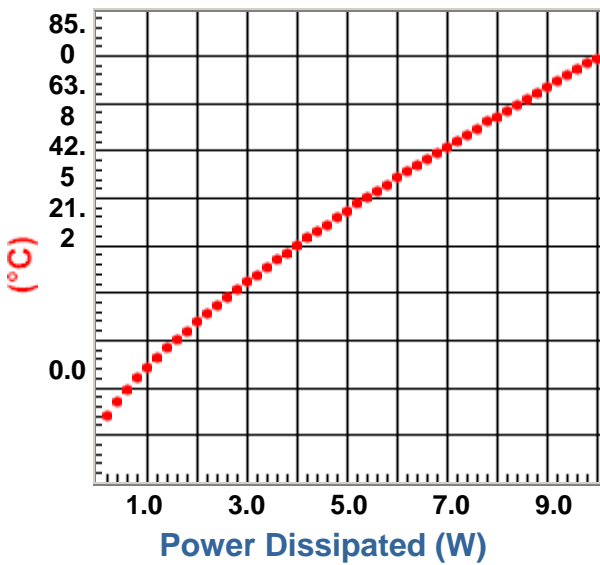

Heat Sink Thermal Resistance

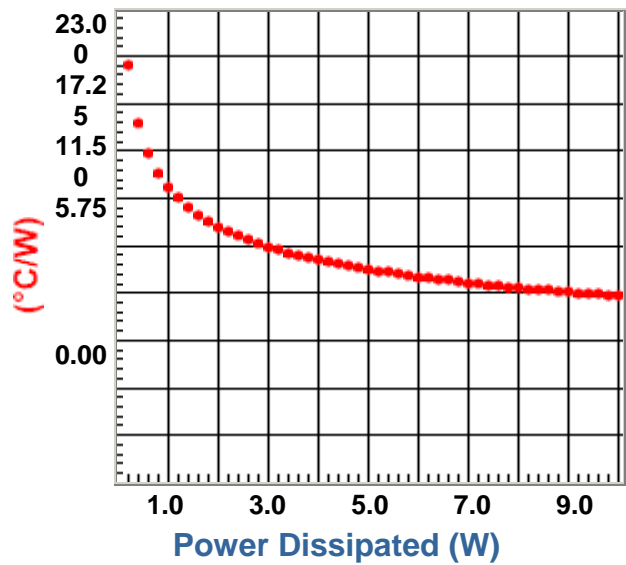

## Forced Convection

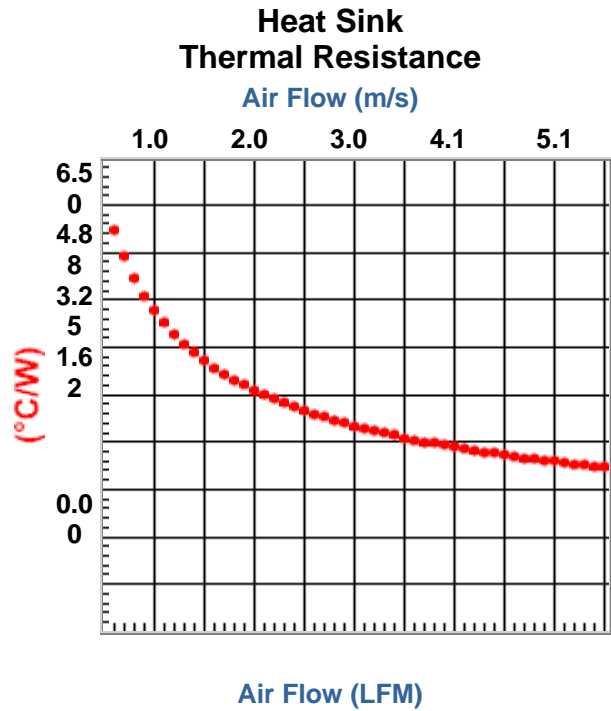
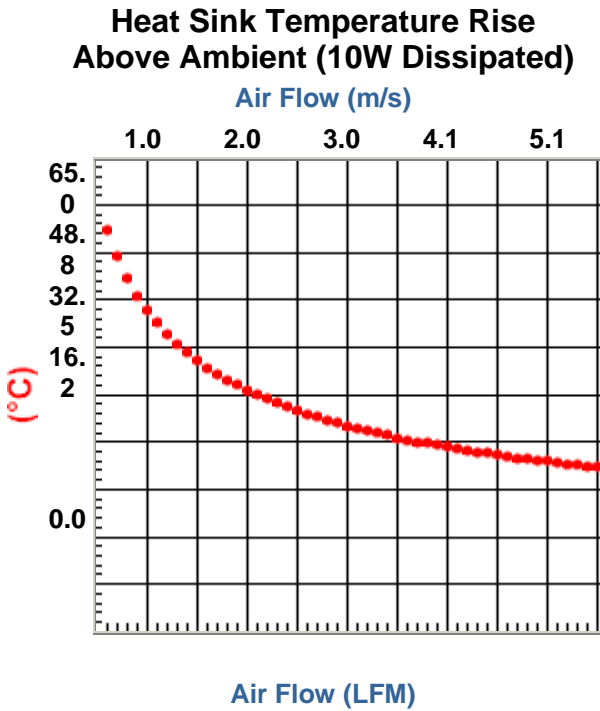

## Building a Part Number

Full Bar Length = 8.20ft

Base Part #	Bar Length	Finish	Length (use zeros for full or half bars)
78265	<u>1</u> Full	<u>E</u> Unfinished	0 0 0 0 0
	<u>2</u> Half	<u>E</u> Unfinished	0 0 0 0 0
	<u>3</u> Custom	<u>B</u> Black Anodized <u>C</u> Gold Chromate <u>U</u> * Unfinished <u>V</u> AavSHIELD <sup>3</sup>	<i>indicate length in inches to three decimal places; 1 5 2 5 0 = 15.250 "</i>

**78265**      —      —      — — — — —

\*For unfinished extrusions with cut lengths other than half bar, the finish designation is a U.

Standard Aavid Thermalloy parts require all 12 positions to be complete.

