

# 3M™ Dri-Shield Moisture Barrier Bag 3400

Sizes on Page 2

## Moisture Barrier Bag ~ Foil

3M's Dri-Shield Moisture Barrier Bag 3400 is designed for dry packaging of electronic devices. Dri-Shield 3400 bags are made from a high barrier foil structure. Bags protect SMD's from moisture and static damage. Flexible structure is easy to vacuum seal. Lot coded for QC traceability.



Dri-Shield 3400

3M™ Moisture Barrier Bag with  
3M™ Humidity Indicator Card and  
3M™ Desiccant



## Standards

Meets electrical and physical requirements of IPC/JEDEC J-STD-033, MIL-PRF-81705 Type 1, EIA 583, EIA 541, EIA 625, and EOS/ESD Standards.

## Specifications

<b>Physical Properties:</b>	Typical Values	
MVTR(g/100 sq.in./24 hrs)	<.0003	ASTM F 1249
Puncture Resistance	>20 lbs	FTMS 101 MTH 2065
Thickness	4.0 mils	3M 008
Tensile Strength	8500 PSI MD	ASTM D-882
	9500 PSI TD	ASTM D-882
Elongation	130 % MD	ASTM D-882
	85 % TD	ASTM D-882
Seam Strength	Pass	MIL-PRF-81705
Heat Sealing Conditions:		
Temperature	300°F - 400°F	
Time	0.6 - 4.5 seconds	
Pressure	30 - 70 PSI	
<b>Electrical Properties:</b>		
Surface Resistivity / Resistance	ASTM D257	or ANSI/ESD STM11.11
Interior	<10 <sup>12</sup> ohms/square	or <10 <sup>11</sup> ohms
Exterior	<10 <sup>12</sup> ohms/square	or <10 <sup>11</sup> ohms
Metal	100 ohms	
Static Shielding	< 30 volts	EIA 541
Static Shielding	< 20 nJ	EOS/ESD S11.31
EMI Attenuation	45 dB	MIL-PRF-81705

### Material Structure

4 mils of static dissipative polymer, aluminum foil, and static dissipative polyethylene provide a very low MVTR. This foil barrier material meets or exceeds the MVTR and EMI/RFI/Static Shielding requirements of IPC/JEDEC J-STD-033 MIL-PRF-81705 Type I, and EIA 583, for static safe, moisture barrier packaging.

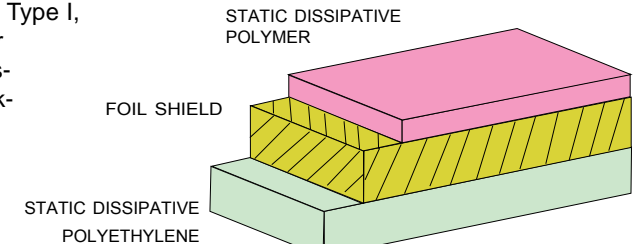

See 3M Data Sheets for these related items:

Humidity Indicator Cards (HIC's)

Desiccant

3M™ Label 113

Vacuum Sealers

## P R O D U C T   D A T A   S H E E T

### Dri-Shield 3400 Moisture Barrier Bag FOIL

**PRODUCT**  
MOISTURE BARRIER BAG, FOIL

**ITEM NUMBER**  
D34(W")(L")

**DATASHEET**  
1161-B

3M Electronic Solutions Division  
6801 River Place Blvd.  
Austin, TX 78726-9000  
US and Canada: 866-722-3736  
Fax: 866-722-3735  
Intl: 919-718-0000; Fax: 919-774-8174  
email: 3Mstaticinfo@mmm.com; www.3M.com/static

3M is a trademark of 3M Company.  
All other trademarks herein are the property  
of their respective owners.



© 2008

# 3M™ Dri-Shield Moisture Barrier Bag 3400

## Moisture Barrier Bag ~ Foil

W"x L" P/N

Please Inquire

## 3M™ Dri-Shield Moisture Barrier Bag 3400

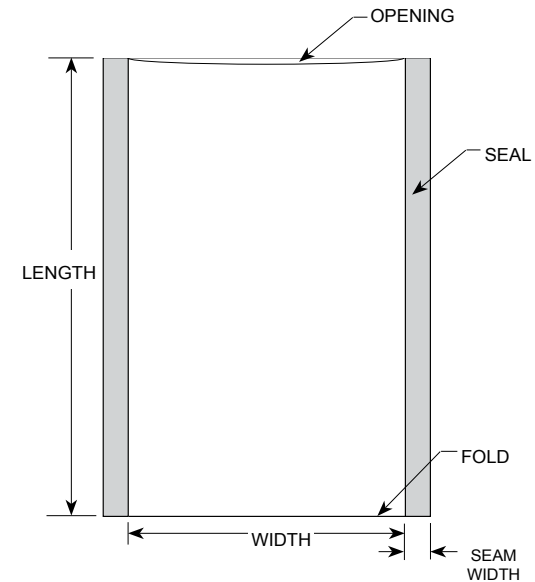

### How Moisture Barrier Bags Work

Moisture barrier bags work by enclosing a device with a metal or plastic shield(s) that has a high resistance to moisture vapor permeation. Dry devices are placed inside this shield, and the moisture-laden air is evacuated. Desiccant filled pouches scavenge the remaining moisture from the bag's interior. Moisture that penetrates the bag is also entrapped by the desiccant. Humidity indicating cards report the effectiveness of the package upon device use. A label on the bag indicates the amount of exposure time devices are allowed prior to use, and the drying (re-baking) time and temperature if the exposure time is exceeded.

As the barrier property improves, the Moisture Vapor Transmission Rate (MVTR) decreases. Bags with lower MVTR provide better barrier. Aluminum foil provides the best MVTR of about 0.0003. Multiple layers of Foil Polyester can provide 0.02 to about 0.005.

Puncture Resistance is an important feature for barrier bags. Sharp tray edges may tear through bags with low puncture resistance.

- All standard sizes in-stock/same day shipment.
- Width is measured from inside seam to inside seam.
- Length is measured from the top edge to the bottom fold.
- Opening is in the "width" dimension.
- Custom bag sizes, custom printing, and custom hot stamping are available.
- Most sizes are packed 100 per case.  
Small sizes are packed 1000 or 500 per case.

## P R O D U C T   D A T A   S H E E T

### Dri-Shield 3400 Moisture Barrier Bag FOIL

**PRODUCT**  
MOISTURE BARRIER BAG, FOIL

**ITEM NUMBER**  
D34(W")(L")

**DATASHEET**  
1161-B

3M Electronic Solutions Division  
6801 River Place Blvd.  
Austin, TX 78726-9000  
US and Canada: **866-722-3736**  
Fax: 866-722-3735  
Intl: 919-718-0000; Fax: 919-774-8174  
email: 3Mstaticinfo@mmm.com; www.3M.com/static

3M is a trademark of 3M Company.  
All other trademarks herein are the property  
of their respective owners.



© 2008